

DATA SHEET

EP7

EP cores and accessories

Supersedes data of September 2004

2008 Sep 01



FERROXCUBE
A YAGEO COMPANY

CORE SETS

Effective core parameters

SYMBOL	PARAMETER	VALUE	UNIT
$\Sigma(l/A)$	core factor (C1)	1.45	mm ⁻¹
V_e	effective volume	165	mm ³
l_e	effective length	15.5	mm
A_e	effective area	10.7	mm ²
A_{min}	minimum area	8.55	mm ²
m	mass of core set	≈ 1.4	g

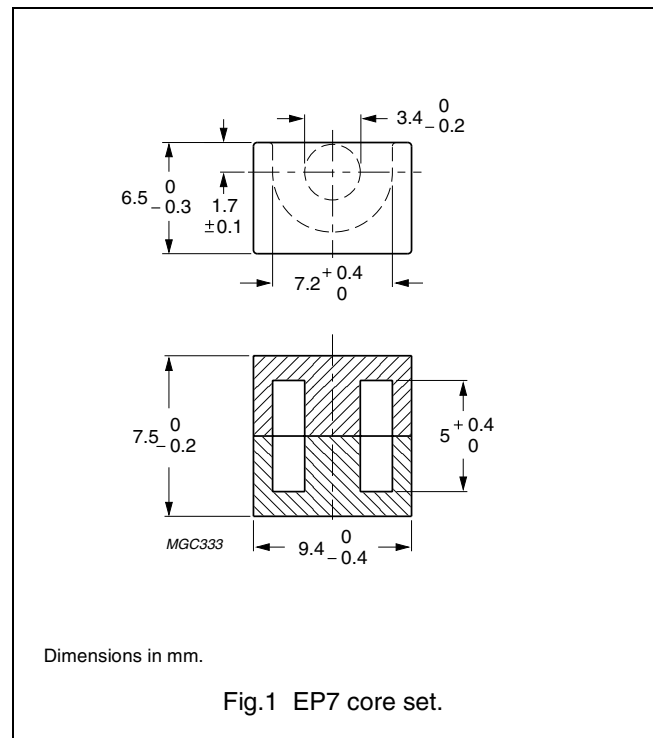

Core sets for filter applications

Clamping force for A_L measurements, 20 ±10 N.

GRADE	A_L (nH)	μ_e	AIR GAP (μ m)	TYPE NUMBER
3B46 <small>des</small>	1500 ±25%	≈ 1730	≈ 0	EP7-3B46

Core sets for general purpose transformers and power applications

Clamping force for A_L measurements, 20 ±10 N.

GRADE	A_L (nH)	μ_e	TOTAL AIR GAP (μ m)	TYPE NUMBER
3C81	25 ±3%	≈ 29	≈ 880	EP7-3C81-E25
	40 ±3%	≈ 46	≈ 480	EP7-3C81-A40
	63 ±3%	≈ 73	≈ 270	EP7-3C81-A63
	100 ±3%	≈115	≈150	EP7-3C81-A100
	160 ±5%	≈184	≈ 90	EP7-3C81-A160
	1300 ±25%	≈ 1500	≈ 0	EP7-3C81
3C91 <small>des</small>	1300 ±25%	≈ 1500	≈ 0	EP7-3C91
3C94	25 ±3%	≈ 29	≈ 880	EP7-3C94-E25
	40 ±3%	≈ 46	≈ 480	EP7-3C94-A40
	63 ±3%	≈ 73	≈ 270	EP7-3C94-A63
	100 ±3%	≈115	≈150	EP7-3C94-A100
	160 ±5%	≈184	≈ 90	EP7-3C94-A160
	1200 ±25%	≈ 1380	≈ 0	EP7-3C94

GRADE	A_L (nH)	μ_e	TOTAL AIR GAP (μm)	TYPE NUMBER
3C96 des	1 120 $\pm 25\%$	≈ 1290	≈ 0	EP7-3C96
3F3	25 $\pm 3\%$	≈ 29	≈ 880	EP7-3F3-E25
	40 $\pm 3\%$	≈ 46	≈ 480	EP7-3F3-A40
	63 $\pm 3\%$	≈ 73	≈ 270	EP7-3F3-A63
	100 $\pm 3\%$	≈ 115	≈ 150	EP7-3F3-A100
	160 $\pm 5\%$	≈ 184	≈ 90	EP7-3F3-A160
	1000 $\pm 25\%$	≈ 1150	≈ 0	EP7-3F3
3F35 des	850 $\pm 25\%$	≈ 980	≈ 0	EP7-3F35

Core sets of high permeability gradesClamping force for A_L measurements, 20 ± 10 N.

GRADE	A_L (nH)	μ_e	TYPE NUMBER
3E27	3400 $\pm 25\%$	≈ 3920	EP7-3E27
3E5	5200 +40/-30%	≈ 5990	EP7-3E5
3E55 des	5200 +40/-30%	≈ 5990	EP7-3E55
3E6	5800 +40/-30%	≈ 6680	EP7-3E6

Properties of core sets under power conditions

GRADE	B (mT) at	CORE LOSS (W) at			
	H = 250 A/m; f = 25 kHz; T = 100 °C	f = 25 kHz; \hat{B} = 200 mT; T = 100 °C	f = 100 kHz; \hat{B} = 100 mT; T = 100 °C	f = 100 kHz; \hat{B} = 200 mT; T = 100 °C	f = 400 kHz; \hat{B} = 50 mT; T = 100 °C
3C81	≥320	≤ 0.04	–	–	–
3C91	≥320	–	≤ 0.11 ⁽¹⁾	≤ 0.06 ⁽¹⁾	–
3C94	≥320	–	≤ 0.014	≤ 0.08	–
3C96	≥340	–	≤ 0.011	≤ 0.06	≤ 0.025
3F35	≥320	–	–	–	≤ 0.015
3F3	≥315	–	≤ 0.02	–	≤ 0.035

Properties of core sets under power conditions (continued)

GRADE	B (mT) at	CORE LOSS (W) at			
	H = 250 A/m; f = 25 kHz; T = 100 °C	f = 500 kHz; \hat{B} = 50 mT; T = 100 °C	f = 500 kHz; \hat{B} = 100 mT; T = 100 °C	f = 1 MHz; \hat{B} = 30 mT; T = 100 °C	f = 3 MHz; \hat{B} = 10 mT; T = 100 °C
3C81	≥320	–	–	–	–
3C91	≥320	–	–	–	–
3C94	≥320	–	–	–	–
3C96	≥340	≤ 0.055	–	–	–
3F35	≥320	≤ 0.02	≤ 0.15	–	–
3F3	≥315	–	–	–	–

Note

1. Measured at 60 °C.

COIL FORMERS

General data

PARAMETER	SPECIFICATION
Coil former material	phenolformaldehyde (PF), glass-reinforced, flame retardant in accordance with "UL 94V-0"; UL file number E41429(M)
Pin material	copper clad steel, tin (Sn) plated
Maximum operating temperature	180 °C, "IEC 60085", class H
Resistance to soldering heat	"IEC 60068-2-20", Part 2, Test Tb, method 1B, 350 °C, 3.5 s
Solderability	"IEC 60068-2-20", Part 2, Test Ta, method 1, 235 °C, 2 s

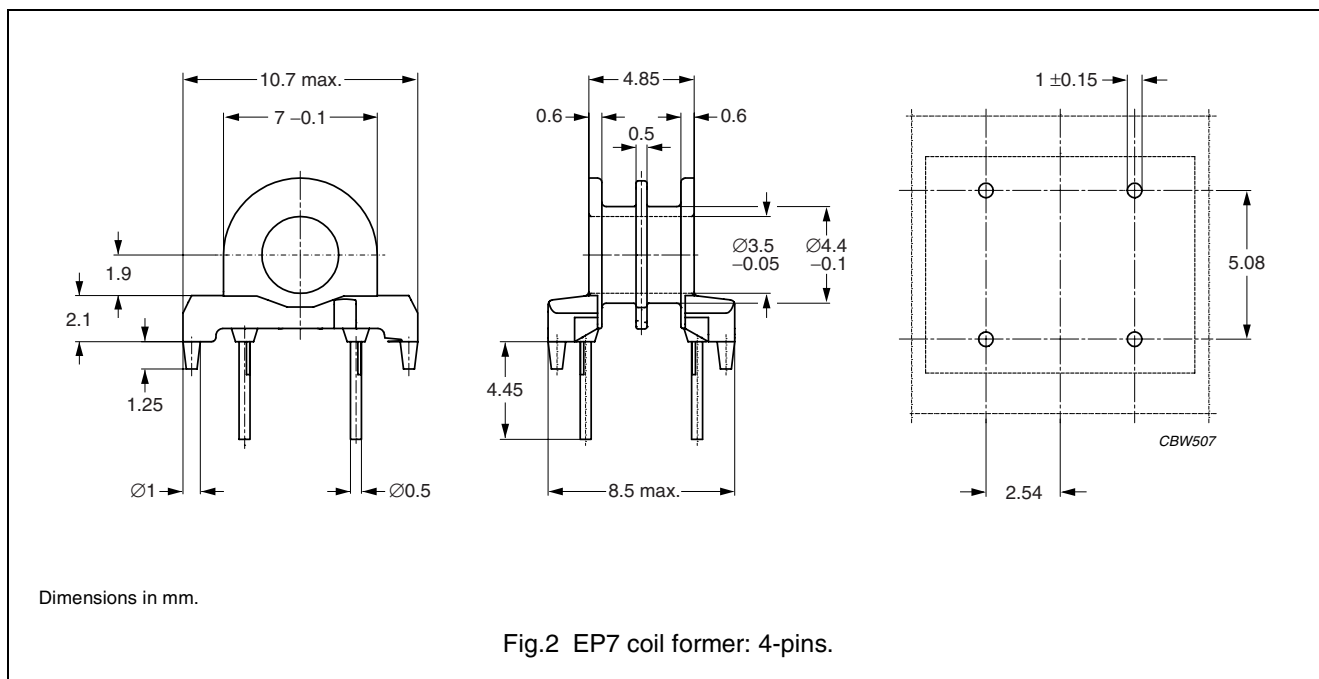

Winding data and area product for 4-pins EP7 coil former

NUMBER OF SECTIONS	WINDING AREA (mm ²)	NOMINAL WINDING WIDTH (mm)	AVERAGE LENGTH OF TURN (mm)	AREA PRODUCT Ae x Aw (mm ⁴)	TYPE NUMBER
2	2 x 1.75	2 x 1.45	17.9	2 x 18.7	CSH-EP7-2S-4P-TA

General data CSH-EP7-1S-6P-B

PARAMETER	SPECIFICATION
Coil former material	phenolformaldehyde (PF), glass-reinforced, flame retardant in accordance with "UL 94V-0"; UL file number E41429(M)
Pin material	copper clad steel, tin (Sn) plated
Maximum operating temperature	180 °C, "IEC 60085", class H
Resistance to soldering heat	"IEC 60068-2-20", Part 2, Test Tb, method 1B, 350 °C, 3.5 s
Solderability	"IEC 60068-2-20", Part 2, Test Ta, method 1, 235 °C, 2 s

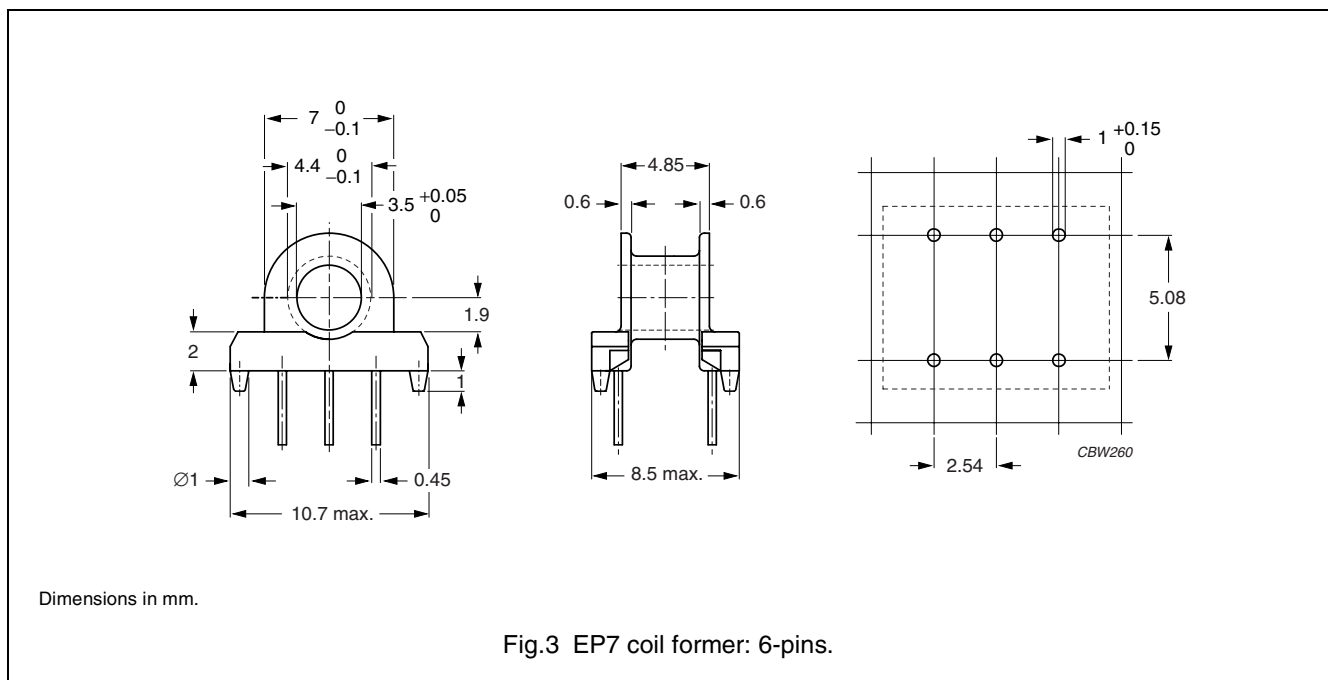

Winding data and area product for 4 and 6-pins EP7 coil former

NUMBER OF SECTIONS	MINIMUM WINDING AREA (mm ²)	NOMINAL WINDING WIDTH (mm)	AVERAGE LENGTH OF TURN (mm)	AREA PRODUCT Ae x Aw (mm ⁴)	TYPE NUMBER
1	4.3	3.4	17.7	46.0	CSH-EP7-1S-6P-BZ
1	4.3	3.4	17.7	46.0	CSH-EP7-1S-4P-BZ

General data for 6-pads EP7 SMD coil former

PARAMETER	SPECIFICATION
Coil former material	phenolformaldehyde (PF), glass reinforced, flame retardant in accordance with "UL 94V-0"; UL file number: E41429 (M)
Solder pad material	copper-clad steel , tin (Sn) plated
Maximum operating temperature	155 °C, "IEC 60085", class F
Resistance to soldering heat	"IEC 60068-2-20", Part 2, Test Tb, method 1B, 350 °C, 3.5 s
Solderability	"IEC 60068-2-20", Part 2, Test Ta, method 1: 235 °C, 2 s

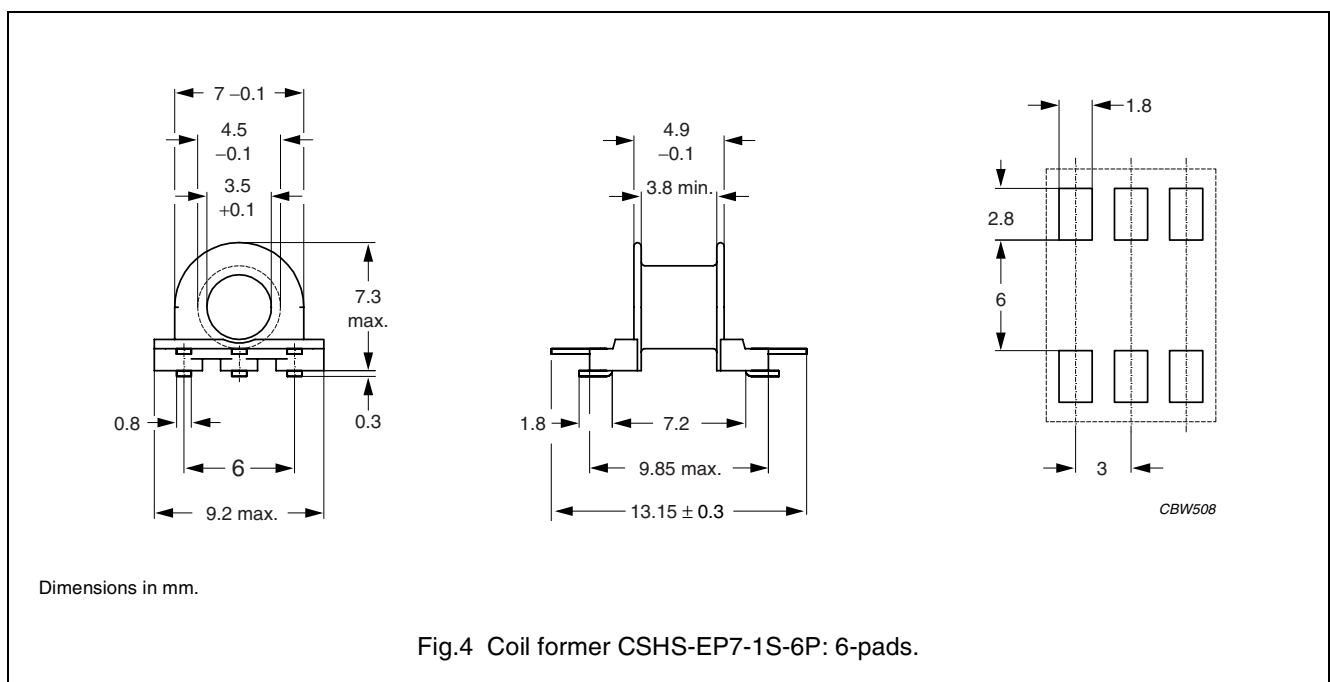

Winding data and area product for 6-pads EP7 SMD coil former

NUMBER OF SECTIONS	WINDING AREA (mm ²)	MINIMUM WINDING WIDTH (mm)	AVERAGE LENGTH OF TURN (mm)	AREA PRODUCT Ae x Aw (mm ⁴)	TYPE NUMBER
1	4.7	3.9	17.9	50.3	CSHS-EP7-1S-6P-Z
1	4.7	3.9	17.9	50.3	CSHS-EP7-1S-5P-Z

MOUNTING PARTS

General data

ITEM	REMARKS	FIGURE	TYPE NUMBER
Mounting clip	stainless steel (CrNi), tin (Sn) plated ; to be used in combination with CSH-EP7-1S-6P-BZ	5	CLI/P-EP7
Mounting clip	stainless steel (CrNi); clamping force ≈ 22 N	6	CLI-EP7

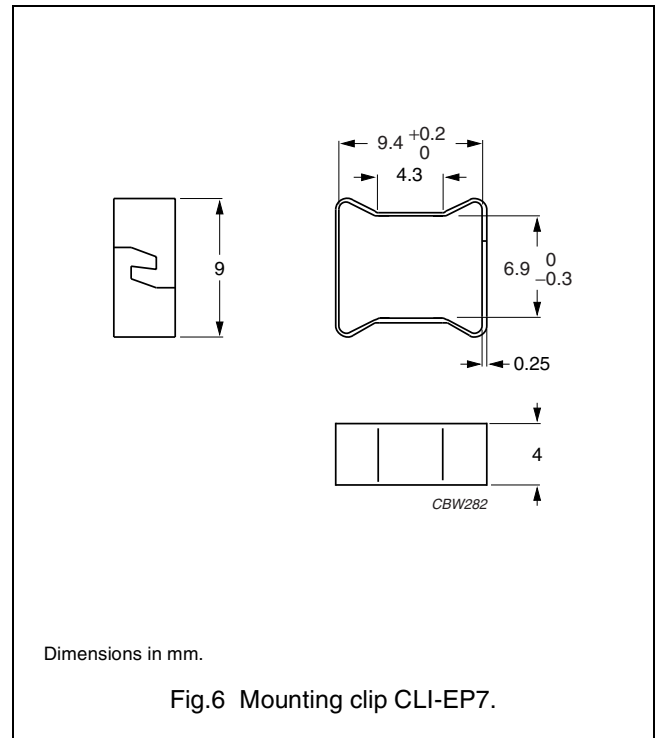
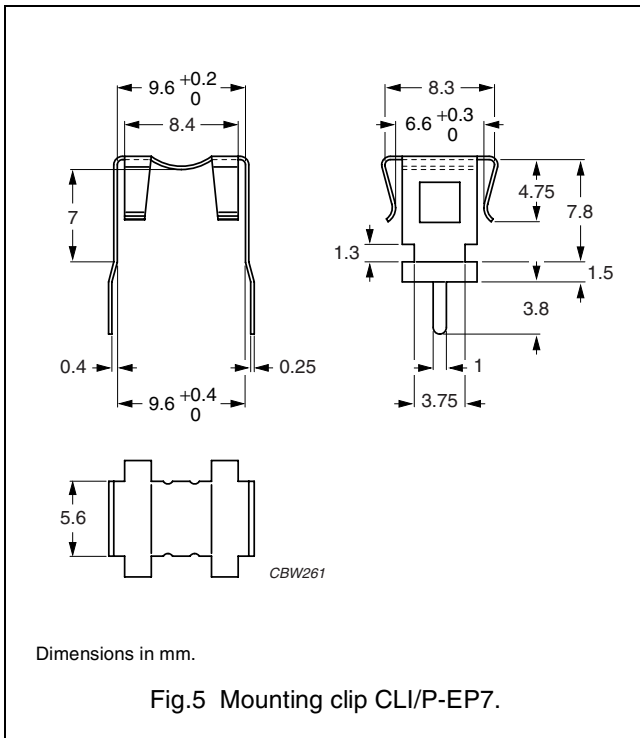



DATA SHEET STATUS DEFINITIONS

DATA SHEET STATUS	PRODUCT STATUS	DEFINITIONS
Preliminary specification	Development	This data sheet contains preliminary data. Ferroxcube reserves the right to make changes at any time without notice in order to improve design and supply the best possible product.
Product specification	Production	This data sheet contains final specifications. Ferroxcube reserves the right to make changes at any time without notice in order to improve design and supply the best possible product.

DISCLAIMER

Life support applications — These products are not designed for use in life support appliances, devices, or systems where malfunction of these products can reasonably be expected to result in personal injury. Ferroxcube customers using or selling these products for use in such applications do so at their own risk and agree to fully indemnify Ferroxcube for any damages resulting from such application.

PRODUCT STATUS DEFINITIONS

STATUS	INDICATION	DEFINITION
Prototype		These are products that have been made as development samples for the purposes of technical evaluation only. The data for these types is provisional and is subject to change.
Design-in		These products are recommended for new designs.
Preferred		These products are recommended for use in current designs and are available via our sales channels.
Support		These products are not recommended for new designs and may not be available through all of our sales channels. Customers are advised to check for availability.